

GLANTRIBE®



FRUIT PRESS

MODEL NO: FP6B & FP12

PART NO: 3500320 & 3500325

USER INSTRUCTIONS



ORIGINAL INSTRUCTIONS

GC0318 ISS 2

INTRODUCTION

Thank you for purchasing this CLARKE product.

Before attempting to use this product, please read this manual thoroughly and follow the instructions carefully. In doing so you will ensure the safety of yourself and that of others around you, and you can look forward to your purchase giving you long and satisfactory service.

ASSEMBLY AND USE

- 1 Trunnion
- 2 Pressure Plate
- 3 Threaded Centre Rod
- 4 Wooden Blocks (2 x Pairs)
- 5 Collar
- 6 Screw
- 7 Steel Band
- 8 Cage Slat
- 9 Base
- 10 Handle
- 11 Nylon Washer
- 12 Mesh Sack (Not Shown)

Before building up the press components, the threaded central rod must be fitted to the base. A

24mm spanner or a suitable adjustable wrench will be required for this.

The legs should be bolted or screwed to a firm, solid base, using the holes in the feet. (bolts not supplied)

Put the mesh sack, containing the fruit, into the cage and hanging over the sides. Press down the fruit by hand. Harder fruits - apple, pear etc., should be cut into small pieces and ideally crushed using a mallet or shredder before placing in the sack.

Place the collars (5) on top of the fruit, ensuring they are central within the cage, then add the wooden blocks (4), (if there is sufficient room) followed by

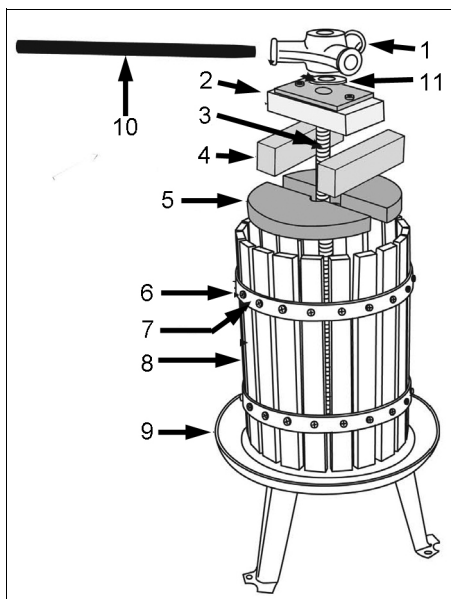

the pressure plate (2) on top of these, as shown in the illustration. Place a container beneath the outlet spout in the base (9) ready to collect the juice.

Screw on the trunnion (1) and rotate the handle (10) to press the fruit down into the cage. Never use an extension bar on the handle. The second pair of blocks provided may be inserted when space allows, to force the collar as near the base of the press as possible. If the blocks (4) were not used for the first pressing, unscrew the trunnion, sufficient for more blocks to be inserted, then screw down again.

After use, the complete press must be thoroughly washed in a mild detergent, rinsed in clean water and dried.

If left unused for prolonged periods, coat all metal components with a thin film of vegetable oil and store in a clean, dry environment. Check the press's condition before using again and if mould is apparent, wash thoroughly, rinse, dry and apply a film of fresh vegetable oil to its metal components.

PRODUCT HYGIENE

IMPORTANT: Before use, ALL components must be scrupulously clean and any traces of old oil removed to avoid the possibility of contamination of the produce. Rinse thoroughly in clean water.

ENVIRONMENTAL PROTECTION

Do not dispose of this product with general household waste at the end of its life. This product contains valuable raw materials and should be disposed of appropriately at a recognised disposal facility.

SPARE PARTS

If required, spare parts are available from your Clarke dealer.

GUARANTEE

This product is guaranteed against faulty manufacture for a period of 12 months from the date of purchase. Please keep your receipt which will be required as proof of purchase.

This guarantee is invalid if the product is found to have been abused or tampered with in any way, or not used for the purpose for which it was intended.

Faulty goods should be returned to their place of purchase, no product can be returned to us without prior permission. This guarantee does not effect your statutory rights.

A SELECTION FROM THE VAST RANGE OF

Clarke®

QUALITY PRODUCTS

AIR COMPRESSORS

From DIY to industrial, Plus air tools, spray guns and accessories.

GENERATORS

Prime duty or emergency standby for business, home and leisure.

POWER WASHERS

Hot and cold, electric and engine driven - we have what you need

WELDERS

Mig, Arc, Tig and Spot. From DIY to auto/industrial.

METALWORKING

Drills, grinders and saws for DIY and professional use.

WOODWORKING

Saws, sanders, lathes, mortisers and dust extraction.

HYDRAULICS

Cranes, body repair kits, transmission jacks for all types of workshop use.

WATER PUMPS

Submersible, electric and engine driven for DIY, agriculture and industry.

POWERTOOLS

Angle grinders, cordless drill sets, saws and sanders.

STARTERS/CHARGERS

All sizes for car and commercial use.

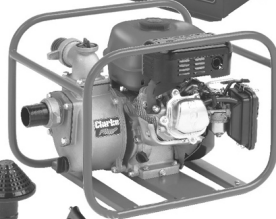

PARTS & SERVICE: 0208 988 7400

E-mail: Parts@clarkeinternational.com or Service@clarkeinternational.com

SALES: UK 01992 565333 or Export 00 44 (0)1992 565335

Clarke INTERNATIONAL Hemnall Street, Epping, Essex CM16 4LG
www.clarkeinternational.com